



*gridbots*



# HYDRO BLAST

BLASTING/RUST REMOVAL ROBOT



# HYDRO BLAST

BLASTING/RUST REMOVAL ROBOT

Gridbots HydroBLAST is an enormously powerful and useful robot which can perform hydroblasting of various magnetic surfaces of the chimneys, bridge structures, Petroleum, Acid and many other kind of container tanks online for paint coat, rust and lacquer removal in fastest and most optimum manner.

It utilises Ultra High pressure water jet for such operations and provide realtime video feed to the operator for evaluation of the process impact.

The robot utilises powerful rare earth magnets to adhere to the surface and move at inclined and vertical surface easily.

The robot can also be used for the painting and coating applications after surface preparation.

The robot can operate on a portable power supply and just requires high pressure water jetting source which can perform as per the operation requirement.

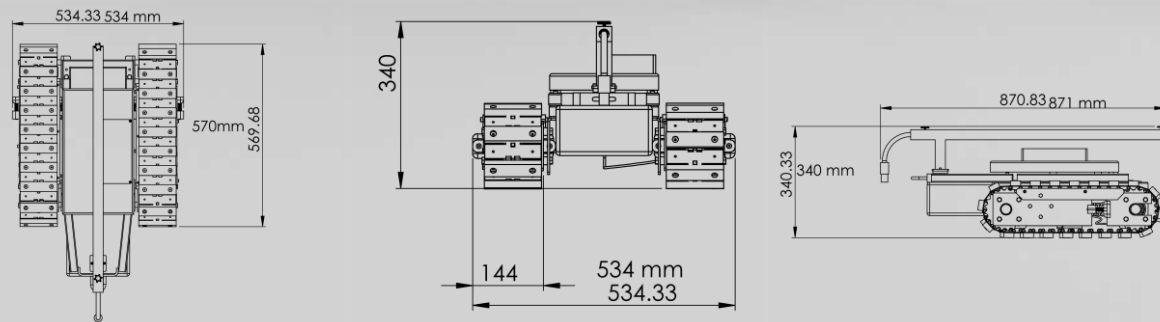
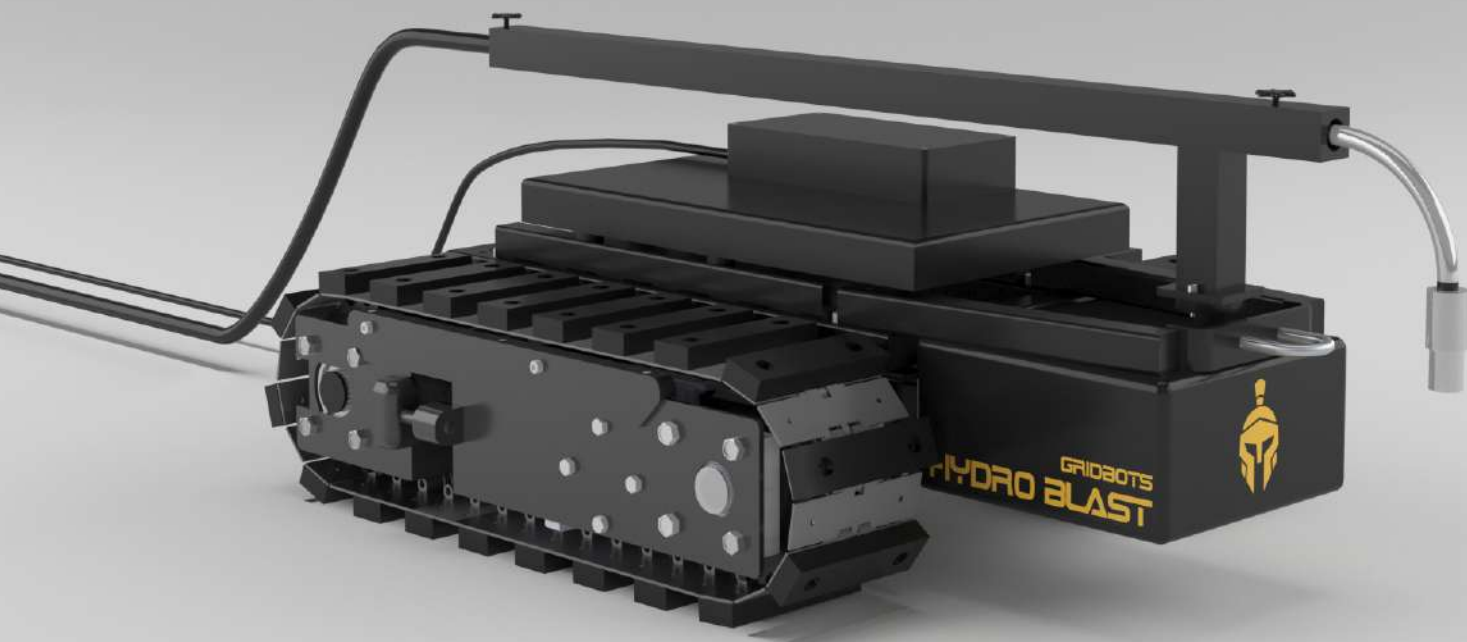

## MOST POWERFUL AND SAFEST WAY TO HYDROBLAST YOUR ASSETS



MAINTAIN AND CONDITION YOUR TANKS/CHIMNEYS



ACHIEVE FULL POWER OF HYDRO CLEANING



SAVE MONEY ON MANUAL OPERATIONS



100% SECURE

100% SAFE

## ROBOT IN OPERATION



INSPECTION  
CLEANING  
RESTORATION  
PAINTING  
COATING

GRIDBOTS HYDRO BLAST

RUSTED SURFACE / PAINTED SURFACE

## VARIANTS

Wheels  
**Four Powered Wheels/2 Powered Tracks**

Payload  
**Upto 50 Kg**

Magnets Used  
**Array of NDFeB Magnets**

Crawling Speed  
**Maximum of 10 MM/Sec**

Encoder Motion Resolution  
**0.1 mm Increments**

IMU  
**100Hz - 6 DOF**

Provide Cable Length  
**100/200 Meters**

Robot Weight  
**30 Kgs**

Power  
**24V-50A [1 KW - Peak]**

Cameras  
**2 [1 - Front Down Facing. 1- Rear Down Facing]**

Remote Control  
**Tether Cabled [Kevlar wire rope]**

Build Material  
**Aircraft Grade Aluminum and Ss316**

## SAFETY

TOF Sensors  
**6x**

Impact Sensor  
**1x**

E-Stop  
**2x**

## ENVIRONMENTAL

IP Rating  
**65**

Temperature  
**5°C to 65°C**

Humidity  
**95%, Non-Condensing**



HYDRO BLAST

PUMP UNIT

CONTROL UNIT

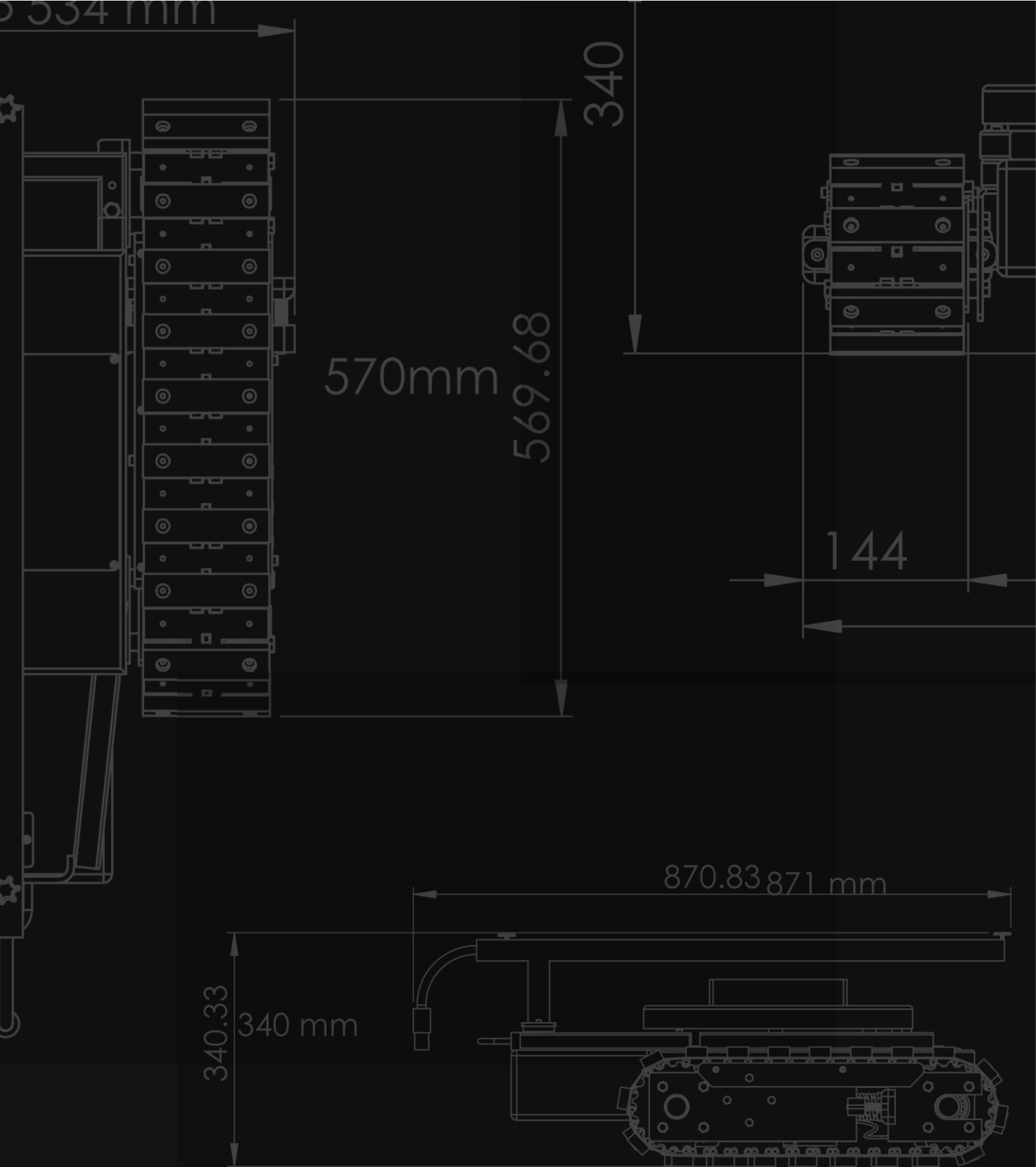

## GRIDBOTS TECHNOLOGIES PVT. LTD.

### Main Office Address

Office #306, Maharana Pratap Complex,  
Behind V.S. Hospital, Ashram Road,  
Ahmedabad - 380006,  
Gujarat, India.

### Factory Address

Survey No. 157, Fatehwadi,  
Kismat Estate, Near Alwish Motors,  
Sanathal-Bakroal Ring Road,  
Ahmedabad-382210.

### Contact

M. :+919924826584  
Email Id : [contact@gridbots.com](mailto:contact@gridbots.com)  
Website : [www.gridbots.com](http://www.gridbots.com)